

# MagneW 3000 PLUS Smart Electromagnetic Flowmeter Detector (General, FM/CSA Nonincendive Approval)

## Model MGG18, MGG19

### OVERVIEW

The MagneW 3000 PLUS electromagnetic flowmeter detector is a high performance, highly reliable flowmeter developed with Yamatake's proven MagneW 3000 flow measurement technologies. Model MGG18 (watertight model) and model MGG19 (submersible model) offer superior process flowrate measurement and couple with a wide range of MagneW 3000 PLUS converters.

### FEATURES

#### High performance lining

- A new, exclusive high quality lining technology and a special mirror-finish PFA lining offers higher anti-adhesive properties than existing models.
- The mirror-finish PFA lining is particularly applicable for measurement of sticky pulp and gypsum slurries.
- Only pure white PFA with no additives is used to make new linings.
- The successful embedded punch plate that offers proven performance under conditions such as rapid thermal change and negative pressure. PFA linings with diameter ranges from 2.5 mm to 600 mm (0.1 to 24 inches) are available, making selection of the best lining easy for a wide variety of applications.

#### Replacement interfacing detector (optional)

- This detector can replace the detector interfaces of our existing models and those of other manufacturers. Please consult your Yamatake representative for details.

#### Rugged detector structure

- A stainless steel case has been adopted for sizes of 2.5 mm to 200 mm (0.1 to 8 inches).
- A watertight structure effective for environments where moisture and condensation tends to occur is used for the water-tight model (model MGG18).

#### A wide variety of piping connections

- A hose or union joint or clamp can be selected for very small size models (diameters of 2.5 to 15 mm (0.1 to 1/2 inches)).
- A flange structure is available for all sizes (sizes of 2.5 to 1100 mm (0.1 to 44 inches)).
- A wafer construction can be also selected (sizes of 2.5 to 200 mm (0.1 to 8 inches)).
- Sizes of 65 and 125 mm (2½ and 5 inches) have been added to our existing product lineup.



Size 2.5 to 600 mm (0.1 to 24 inches)

Size 700 to 1100 mm (28 to 44 inches)

#### Compatibility

- Remote model converters can be used in combination with our conventional converters. Please consult your Yamatake representative for details.

#### Type of protection

Model MGG 18/19 are suitable for use in FM/CSA Nonincendive Class I, Division 2, Groups A, B, C and D; Class II, Division 2, Groups F and G; Class III, Division 2.

#### Improved Accuracy Specification

The standard accuracy is +/- 0.5% of rate. Also available is an optional high accuracy calibration rated at +/- 0.35% of rate (sizes of 40mm to 350mm (1½ to 14 inches), combined with MGG14C).

**APPLICATIONS****Pulp and paper**

Pulp liquids, chemicals, corrosive liquids, industrial water, wastewater, etc.

**Petroleum/petrochemical/chemicals**

Corrosive liquids, dyestuffs, chemicals, industrial water, waste water, etc.

**Public utilities**

Water supply systems, sewage systems, community drainage, human waste, sludge, sediment slurry, regulation of total effluent, etc.

**Food**

Potable water, light, medium and high density fluids, industrial water, waste water, etc.

**Steel/nonferrous metals/ceramics**

Aluminum slurry, cooling water, industrial water, corrosive liquids, wastewater, etc.

**Machinery/equipment/electric machinery**

Corrosive liquids, cooking water, circulating water, industrial water, wastewater, etc.

**Construction**

Building material slurry, sediment slurry, cement slurry, industrial water, etc.

**Shipbuilding**

Sediment slurry etc.

**Electric power**

Corrosive liquids, cooling water, industrial water, wastewater, etc.

**Gas**

Circulating water for air conditioning, etc.

**FUNCTIONAL SPECIFICATIONS****Type of protection****Model MGG18**

JIS C 0920 watertight model  
NEMA TYPE4X, IEC IP67

**Model MGG19**

JIS C 0920 submersible model  
NEMA TYPE6P, IEC IP68

**FM approval for both**

Nonincendive for Class I, Division 2, Groups A, B, C and D  
Suitable for Class II, Division 2, Groups F and G  
Suitable for Class III, Division 2, indoor and outdoor (type 4X) hazardous locations.

**CSA approval for both**

Nonincendive for Class I, Division 2, Groups A, B, C, and D  
For Class II, Division 2, Groups E, F and G  
For Class III for used with non-flammable process fluids.

**Line size**

2.5, 5, 10, 15, 25, 40, 50, 65, 80, 100, 125, 150, 200, 250, 300, 350, 400, 450, 500, 600, 700, 800, 900, 1000, 1100 mm  
(0.1, 0.2, 3/8, 1/2, 1, 1½, 2, 2½, 3, 4, 5, 6, 8, 10, 12, 14, 16, 18, 20, 24, 28, 32, 36, 40, 44 inches)

**Flange rating**

JIS 10K, JIS 16K, JIS 20K, JIS 30K,  
JPI 150, JPI 300, ANSI 150, ANSI 300,  
DIN PN10, DIN PN16, DIN PN25, DIN PN40  
(Size 2.5 to 50 mm (0.1 to 2 inches))

JIS 10K, JIS 16K, JIS 20K, JIS 30K, JIS G3451 F12  
JPI 150, JPI 300, ANSI 150, ANSI 300,  
DIN PN10, DIN PN16, DIN PN25, DIN PN40  
(Size 80 to 200 mm (3 to 8 inches))

JIS 10K, JIS 16K, JIS 20K, JIS G3451 F12  
JPI 150, JPI 300, ANSI 150, ANSI 300,  
DIN PN10, DIN PN16, DIN PN25  
(Size 250 to 600 mm (10 to 24 inches), PFA/ETFE lining)

JIS 10K, JIS G3451 F12,  
JPI 150, ANSI 150, DIN PN10  
(Size 250 to 600 mm (10 to 24 inches), chloroprene rubber lining)

**Measurement flow range**

Refer to the minimum/maximum set ranges shown in the table below

Size		Minimum flow velocity range is 0 to 0.1 m/s (0 to 0.33 ft/s)		Maximum flow velocity range is 0 to 10 m/s (0 to 32.8 ft/s)		Conversion factor K
		Minimum range		Maximum range		
mm	inch	m <sup>3</sup> /h	GPM	m <sup>3</sup> /h	GPM	
2.5	0.1	0 to 0.001768	0 to 0.007782	0 to 0.1767	0 to 0.7781	56.59
5	0.2	0 to 0.007069	0 to 0.03113	0 to 0.7068	0 to 3.112	14.15
10	3/8	0 to 0.02825	0 to 0.1246	0 to 2.827	0 to 12.45	3.537
15	1/2	0 to 0.06362	0 to 0.2802	0 to 6.361	0 to 28.01	1.572
25	1	0 to 0.1768	0 to 0.7782	0 to 17.67	0 to 77.81	0.5659
40	1½	0 to 0.4524	0 to 1.993	0 to 45.23	0 to 199.2	0.2210
50	2	0 to 0.7069	0 to 3.113	0 to 70.68	0 to 311.2	0.1415
65	2½	0 to 1.195	0 to 5.261	0 to 119.4	0 to 526.0	0.08371
80	3	0 to 1.810	0 to 7.969	0 to 180.9	0 to 796.8	0.05526
100	4	0 to 2.828	0 to 12.46	0 to 282.7	0 to 1245	0.03537
125	5	0 to 4.418	0 to 19.46	0 to 441.7	0 to 1945	0.02264
150	6	0 to 6.362	0 to 28.02	0 to 636.1	0 to 2801	0.01572
200	8	0 to 11.31	0 to 49.81	0 to 1130	0 to 4980	0.008842
250	10	0 to 17.68	0 to 77.82	0 to 1767	0 to 7781	0.005659
300	12	0 to 25.45	0 to 112.1	0 to 2544	0 to 11205	0.003930
350	14	0 to 34.64	0 to 152.6	0 to 3463	0 to 15251	0.002887
400	16	0 to 45.24	0 to 199.3	0 to 4523	0 to 19920	0.002210
450	18	0 to 57.26	0 to 252.2	0 to 5725	0 to 25211	0.001747
500	20	0 to 70.69	0 to 311.3	0 to 7068	0 to 31125	0.001415
600	24	0 to 101.8	0 to 448.3	0 to 10178	0 to 44820	0.0009824
700	28	0 to 138.6	0 to 610.1	0 to 13854	0 to 61005	0.0007218
800	32	0 to 181.0	0 to 796.9	0 to 18095	0 to 79680	0.0005526
900	36	0 to 229.1	0 to 1009	0 to 22902	0 to 100846	0.0004366
1000	40	0 to 282.8	0 to 1246	0 to 28274	0 to 124501	0.0003537
1100	44	0 to 342.2	0 to 1507	0 to 34211	0 to 150646	0.0002923

Flow conversion Velocity V(m/s) = K × Q      K = Flow conversion factor =  $\frac{1}{3600} \times \frac{4}{\pi D^2}$

Q = Flow rate (m<sup>3</sup>/h)

**Temperature range and pressure range of process fluid**

Size 2.5 to 10 mm (0.1 to 3/8 inch)

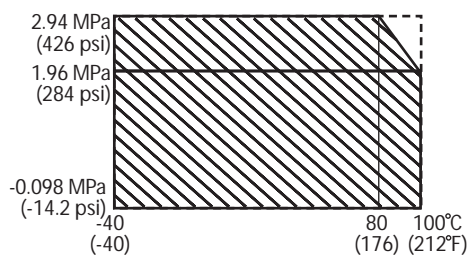

Size 250 to 1100 mm (10 to 44 inches)

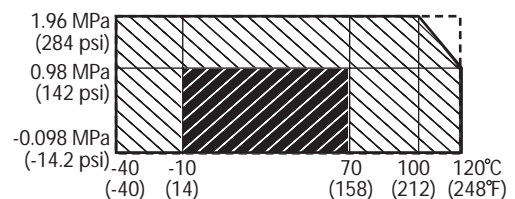

Size 15 to 200 mm (1/2 to 8 inches)

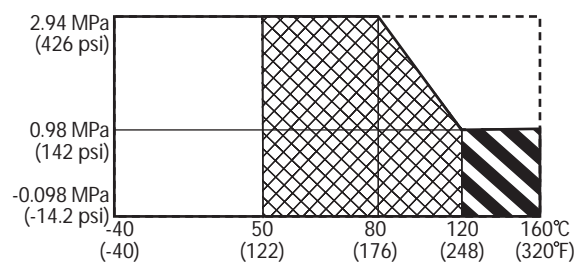

- Chloroprene rubber and PFA / ETFE lining
- Polyurethane rubber and PFA / ETFE lining
- PFA/ETFE lining
- PFA lining
- PFA lining (Remote model only)
- Special products

**Ambient temperature limits**

-25 to +60°C (-13 to +140°F) (integral model)  
 -30 to +80°C (-22 to +176°F) (remote model, PFA lining)  
 30 to +60°C (-22 to +140°F) (remote model, polyurethane rubber lining/chloroprene rubber lining)

**Ambient humidity limits**

5 to 100% RH

**Measurable electrical conductivity**

Combined with model MGG14C converter  
 3 μS/cm or more

**Optional specifications**

**Test report**

Calibration certificate, withstand voltage test, insulation resistant, hydrostatic pressure test, physical inspection are included.

**Traceability certificate**

The following three documents are included.

- Traceability System Chart
- Traceability Certificate
- Test Report

**Material certificate**

Material certificate for electrode/grounding ring

**Gasket for plastic piping**

When the detector is being mounted on plastic pipe, attach this gasket between the lining and the grounding ring, and between the grounding ring and the plastic pipe flange.

**Attaching the tag number to the terminal box**

Stamp the tag with the specified number and attach to the terminal box. The maximum number of characters of the tag number is 8.

**Attaching the tag number to the neck section**

Stamp the tag with the specified number and attach to the neck section of the detector with stainless wire. The maximum number of characters of the tag number is 16.

**PERFORMANCE SPECIFICATIONS**

**Accuracy**

(in combination with the model MGG14C converter)  
 <Size 2.5 to 15 mm (0.1 to 1/2 inch)>

Vs = Velocity of setting range

Vs (m/s)	Velocity during measurement ≥ Vs × 40%	Velocity during measurement ≤ Vs × 40%
1.0 ≤ Vs ≤ 10	±0.5% of rate	±0.2% of Vs
0.1 ≤ Vs ≤ 1.0	±(0.1/Vs+0.4)% of rate	±0.4(0.1/Vs+0.4)% of Vs

<Size 25 to 600 mm (1 to 24 inches)>

Vs = Velocity of setting range

Vs (m/s)	Velocity during measurement ≥ Vs × 40%	
	Standard Accuracy (Calibration Code A)	*)High Accuracy (Calibration Code U)
1.0 ≤ Vs ≤ 10	±0.5% of rate	±0.35% of rate
0.1 ≤ Vs ≤ 1.0	±(0.1/Vs+0.4)% of rate	±(0.1/Vs+0.25)% of rate

Vs (m/s)	Velocity during measurement ≤ Vs × 40%	
	Standard Accuracy (Calibration Code A)	*)High Accuracy (Calibration Code U)
1.0 ≤ Vs ≤ 10	±0.1% of Vs	±0.07% of Vs
0.1 ≤ Vs ≤ 1.0	±0.2(0.1/Vs+0.4)% of Vs	±0.2(0.1/Vs+0.25)% of Vs

\*)High accuracy calibration is available for sizes of 40 to 350mm (1½ to 14 inches).

Reference Conditions for high accuracy calibration:

- Fluid: Tap water
- Fluid temperature: 15 to 30°C
- Ambient temperature: 15 to 30°C
- Ambient humidity: 30 to 70%
- Length of straight pipe:  
 Upstream > 20 × DN  
 Downstream > 5 × DN  
 (DN: Pipe diameter nominal)
- Properly grounded
- Properly centered

<Size 700 to 1100 mm (28 to 44 inches)>

Vs = Velocity of setting range

Vs (m/s)	Velocity during measurement ≥ Vs × 50%	Velocity during measurement ≤ Vs × 50%
1.0 ≤ Vs ≤ 10	±1.0% of rate	±0.5% of Vs
0.1 ≤ Vs ≤ 1.0	±(0.2/Vs+0.8)% of rate	(0.1/Vs+0.4)% of Vs

**PHYSICAL SPECIFICATIONS****Main body material****Measuring pipe materials**

SUS304 stainless steel

**Flange**

SUS304 stainless steel (size 2.5 to 65 mm (0.1 to 2½ inches))

Carbon steel + corrosion-preventive coating (size 80 to 600 mm (3 to 24 inches))

**Case**

SCS13 stainless steel (size 2.5 to 15 mm (0.1 to 1/2 inch))

SUS304 stainless steel (size 25 to 200 mm (1 to 8 inches))

SS400 carbon steel (size 250 to 1100 mm (10 to 44 inches))

**Terminal box**

Aluminum alloy (remote model)

Finish

**Model MGG18****Standard**

Terminal box

Baked acryl paint

Case (size 250 to 1100 mm (10 to 44 inches))

Polyurethane paint

**Corrosion-resistant**

Terminal box

Baked acryl paint

Case (size 250 to 1100 mm (10 to 44 inches))

Polyurethane paint

**Corrosion-proof**

Terminal box

Baked epoxy paint

Case (size 250 to 1100 mm (10 to 44 inches))

Epoxy paint

**Color**

Light beige (Munsell 4Y7.2/1.3)

**Model MGG19**

Terminal box and case

Corrosion-proof tar epoxy paint, black

**Process wetted material****Lining**

PFA (size 2.5 to 600 mm (0.1 to 24 inches))

ETFE (size 80 to 600 mm (3 to 24 inches))

Polyurethane rubber (size 25 to 200 mm (1 to 8 inches))

Chloroprene rubber (size 250 to 1100 mm (10 to 44 inches))

**Electrode**

SUS316L, Hastelloy C, titanium, zirconium, tantalum, tungsten-carbide, platinum/iridium

**Grounding ring**

SUS316, Hastelloy C, titanium, zirconium, tantalum, platinum

**Union joint**

SUS316 (size 2.5 to 15mm (0.1 to 1/2 inch))

**Hose**

SUS316 (size 2.5 to 15mm (0.1 to 1/2 inch))

**IDF Clamp**

SUS316 (size 2.5 to 15mm (0.1 to 1/2 inch))

**Tri Clamp**

SUS316 (size 2.5 to 15mm (0.1 to 1/2 inch))

**Gasket**

PTFE (if the grounding ring is not made of SUS316)

**O-ring**

Viton rubber (with union joints)

## **INSTALLATION**

### **Electrical connection**

#### **Integral model**

Connected to converter

#### **Remote model**

##### **General model**

G1/2 (PF1/2) internal thread, CM20 internal thread, Pg 13.5 internal thread.

##### **FM/CSA Nonincendive model**

1/2NPT internal thread for model MGG18

Watertight gland for model MGG19

### **Pipe connection**

Wafer (size 2.5 to 200 mm (0.1 to 8 inches))

Flange (size 2.5 to 1100 mm (0.1 to 44 inches))

Union (size 2.5 to 15 mm (0.1 to 1/2 inch))

Hose (size 2.5 to 15 mm (0.1 to 1/2 inch))

IDF Clamp (size 2.5 to 15 mm (0.1 to 1/2 inch))

Tri Clamp (size 2.5 to 15 mm (0.1 to 1/2 inch))

### **Nuts and bolts (for wafer models)**

S20C carbon steel, SUS304 stainless steel

### **Grounding**

Resistance less than 100  $\Omega$

### **Length of straight pipe**

#### **Upstream side**

A minimum five straight pipe diameters

A minimum 10 straight pipe diameters is required if a diffuser/valve/pump is installed upstream side.

#### **Downstream side**

Two straight pipe diameters is recommended.

### **Cable (between remote detector and converter)**

Maximum length 300 m (984 ft)

(depends on fluid conductivity)

Outer diameter 10 to 12 mm (0.4 to 0.47 inch)

#### **Signal cable**

Dedicated cable: MGA12W

(O.D. 11.4 mm, 0.75 mm<sup>2</sup>) or equivalent (CVVS, CEEV etc.)

#### **Excitation cable**

Dedicated cable: MGA12W

(O.D. 10.5 mm, 2 mm<sup>2</sup>) or equivalent (CVV and others)

**For FM/CSA Nonincendive model**

This equipment is suitable for use in Class I, Division 2, Groups A, B, C and D, Class II, Division 2, Groups F and G; Class III, Division 2.

**⚠ CAUTION**

Power supply and internal voltage of ordinary equipment to the earth shall not exceed 250 V AC 50/60Hz, 250 V DC in case of normal /fault conditions.

(Integral type)

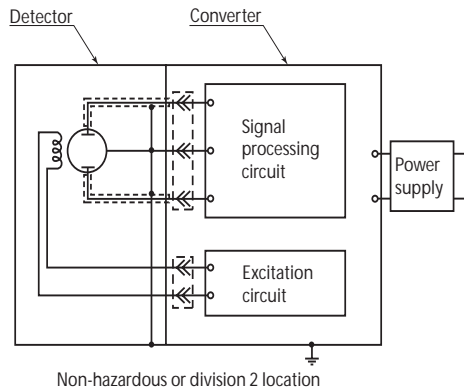

(Remote type)

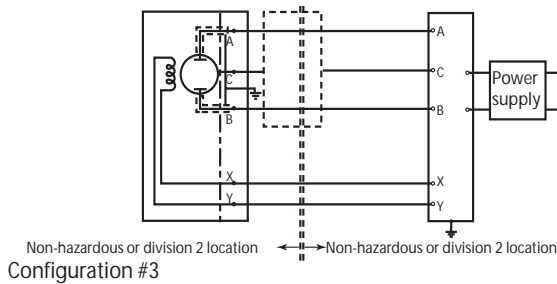
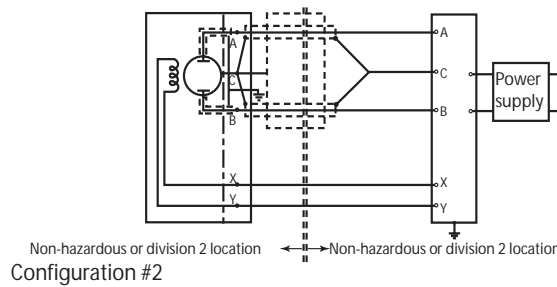
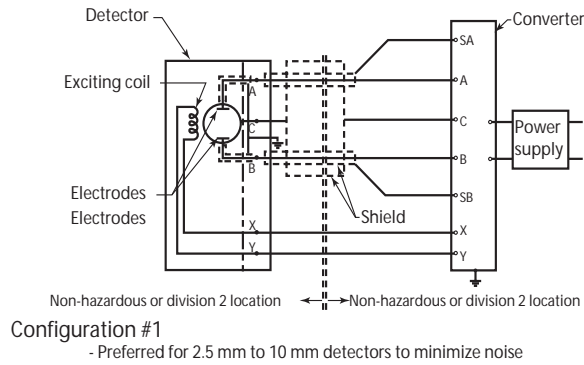

**MODEL SELECTION****Contents of model number table**

## Detector (General model)

Structure / Basic model no.	Lining	Pipe connection	Size	Ref. page
Watertight model MGG18U	PFA	Union / Hose / Clamp	2.5 to 15 mm (0.1 to 1/2 inch)	page 9
Watertight model MGG18D	PFA	Wafer	2.5 to 10 mm (0.1 to 3/8 inch)	page 10
Watertight model MGG18D	PFA / ETFE	Wafer	15 to 200 mm (1/2 to 8 inches)	page 11
Watertight model MGG18F	PFA / ETFE	Flange	15 to 200 mm (1/2 to 8 inches)	page 12
Watertight model MGG18F	PFA / ETFE	Flange	250 to 600 mm (10 to 24 inches)	page 13
Watertight model MGG18D	Polyurethane rubber	Wafer	25 to 200 mm (1 to 8 inches)	page 14
Watertight model MGG18F	Polyurethane rubber	Flange	25 to 200 mm (1 to 8 inches)	page 15
Watertight model MGG18F	Chloroprene rubber	Flange	250 to 600 mm (10 to 24 inches)	page 16
Watertight model MGG18F	Chloroprene rubber	Flange	700 to 1100 mm (28 to 44 inches)	page 17

## Detector (Submersible model)

Structure / Basic model no.	Lining	Pipe connection	Size	Ref. page
Submersible model MGG19D	PFA / ETFE	Wafer	15 to 200 mm (1/2 to 8 inches)	page 18
Submersible model MGG19F	PFA / ETFE	Flange	15 to 200 mm (1/2 to 8 inches)	page 19
Submersible model MGG19F	PFA / ETFE	Flange	250 to 600 mm (10 to 24 inches)	page 20
Submersible model MGG19D	Polyurethane rubber	Wafer	25 to 200 mm (1 to 8 inches)	page 21
Submersible model MGG19F	Polyurethane rubber	Flange	25 to 200 mm (1 to 8 inches)	page 22

Note) All MGG19 models satisfy FM/CSA Nonincendive approval.

	PFA / ETFE lining
	Rubber lining

**Union / Hose / Clamp type (2.5 to 15 mm (0.1 to 1/2 inch)) PFA lining**

Model MGG18U - I II III IV V VI VII VIII IX - X - Y / Options (some options can be selected per each model)

Basic model no.		Selections				Optional selections			
MGG18U									
I	Line size	2.5 mm (0.1 inch)	002						
		5 mm (0.2 inch)	005						
		10 mm (3/8 inch)	010						
		15 mm (1/2 inch)	015						
II	Lining	PFA	P						
III	Piping connection	Union joint R1/2 (PT1/2) external thread	U1						
		Union joint 1/2NPT external thread	U2						
		Union joint R1/2 (PT1/2) internal thread	U3						
		Union joint 1/2NPT internal thread	U4						
		Hose joint	H1						
		IDF clamp	C1						
		Tri clamp	C2						
IV	Electrode	SUS316L	L						
		Hastelloy C	C						
		Titanium	K						
		Zirconium	H						
		Tungsten carbide (only for size 10 mm or upper)	W						
		Others	<input type="checkbox"/>						
V	Grounding ring	SUS316	S						
VI	Electrical connection / watertight gland	Integral type	1						
		Remote type	G1/2 internal thread / without watertight gland	2					
			G1/2 internal thread / with brass (Ni-plated) watertight gland	3					
			G1/2 internal thread / with plastic watertight gland	4					
			1/2NPT internal thread / without watertight gland (Note 1)	5					
			CM20 internal thread / without watertight gland	6					
			Pg 13.5 internal thread / without watertight gland	7					
			G1/2 internal thread / with SUS304 watertight gland	8					
VII	Face-to-face	Standard	A						
VIII	Installation / wiring direction	Integral type	H						
		Remote type	Upstream side (horizontal / vertical piping mounting)	A					
			Downstream side (horizontal / vertical piping mounting)	B					
			Horizontal piping mounting / left side viewed from upstream	C					
			Horizontal piping mounting / right side viewed from upstream	D					
IX	Calibration	Standard	A						
		Others	<input type="checkbox"/>						
X	Finish	Standard	X						
		Corrosion-resistant finish	1						
		Corrosion-proof finish	2						

Options		
Yamatake version (must be selected)	Y	
Calibration certificate (sent to ordering location separately)	A	
Traceability certificate for detector	B	
Material certificate (only for electrodes and ground rings)	C	
Attachment of the TAG number to the terminal box for detector (Note 2)	K	
Attachment of the TAG number plate to neck section for detector	L	

Note) 1. Must be selected for CSA/FM NI approval  
 2. Must be selected for Tag no. requirement

**Wafer type (2.5 to 10 mm (0.1 to 3/8 inch)) PFA lining**

Model MGG18D - I II III IV V VI VII VIII IX - X XI - Y / Options (some options can be selected per each model)

Basic model no.		Selections				Optional selections				
MGG18D										
I	Line size	2.5 mm (0.1 inch)	002							
		5 mm (0.2 inch)	005							
		10 mm (3/8 inch)	010							
II	Lining	PFA				P				
III	Piping connection	Wafer JIS 10K							11	
		Wafer JIS 20K							12	
		Wafer JIS 30K							13	
		Wafer JIS 10/20K for 10 mm flange							14	
		Wafer JIS 30K for 10 mm flange							15	
		Wafer ANSI 150							21	
		Wafer ANSI 300							22	
		Wafer DIN PN10							41	
		Wafer DIN PN16							42	
		Wafer DIN PN25							43	
		Wafer DIN PN40							44	
		Wafer DIN PN10/16/25/40 for 10 mm flange							45	
		Wafer JPI 150							61	
Wafer JPI 300							62			
IV	Electrode	SUS316L							L	
		Hastelloy C							C	
		Titanium							K	
		Zirconium							H	
		Tantalum							T	
		Tungsten carbide (only for size 10 mm)							W	
		Platinum iridium							P	
		Others							<input type="checkbox"/>	
V	Grounding ring	SUS316							S	
		Hastelloy C							C	
		Titanium							K	
		Zirconium							H	
		Tantalum							T	
		Platinum iridium							P	
		Others							<input type="checkbox"/>	
VI	Electrical connection / watertight gland	Integral type							1	
		Remote type	G1/2 internal thread / without watertight gland							2
			G1/2 internal thread / with brass (Ni-plated) watertight gland							3
			G1/2 internal thread / with plastic watertight gland							4
			1/2NPT internal thread / without watertight gland (Note 1)							5
			CM20 internal thread / without watertight gland							6
			Pg 13.5 internal thread / without watertight gland							7
			G1/2 internal thread / with SUS304 watertight gland							8
VII	Face-to-face dimensions	Standard							A	
		Others							<input type="checkbox"/>	
VIII	Installation / wiring direction	Integral type							H	
		Remote type	Upstream side (horizontal / vertical piping mounting)							A
			Downstream side (horizontal / vertical piping mounting)							B
			Horizontal piping mounting / left side viewed from upstream							C
Horizontal piping mounting / right side viewed from upstream							D			
IX	Calibration	Standard							A	
		Others							<input type="checkbox"/>	
X	Finish	Standard							X	
		Corrosion-resistant finish							1	
		Corrosion-proof finish							2	
XI	Bolt / nut	None							X	
		Carbon steel							1	
		SUS304							2	

Options		
	Yamatake version (must be selected)	Y
	Calibration certificate (sent to ordering location separately)	A
	Traceability certificate for detector	B
	Material certificate (only for electrodes and ground rings)	C
	With gasket for plastic piping	J
	Attachment of the TAG number to the terminal box for detector (Note 2)	K
	Attachment of the TAG number plate to neck section for detector	L

Note) 1. Must be selected for CSA/FM NI approval  
 2. Must be selected for Tag no. requirement

**Wafer type (15 to 200 mm (1/2 to 8 inches)) PFA / ETFE lining**

Model MGG18D - I II III IV V VI VII VIII IX - X XI - Y / Options (some options can be selected per each model)

Basic model no.		Selections						Optional selections	
MGG18D									
I	Line size	15 mm (1/2 inch)	015						
		25 mm (1 inch)	025						
		40 mm (1½ inches)	040						
		50 mm (2 inches)	050						
		65 mm (2½ inches)	065						
		80 mm (3 inches)	080						
		100 mm (4 inches)	100						
		125 mm (5 inches)	125						
		150 mm (6 inches)	150						
	200 mm (8 inches)	200							
II	Lining	ETFE (Size 80 to 200 mm (3 to 8 inches))	E						
		PFA	P						
III	Piping connection	Wafer JIS 10K	11						
		Wafer JIS 20K	12						
		Wafer JIS 30K	13						
		Wafer ANSI 150	21						
		Wafer ANSI 300	22						
		Wafer JIS G3451 F12 (size 80 mm or larger)	31						
		Wafer DIN PN10	41						
		Wafer DIN PN16	42						
		Wafer DIN PN25	43						
		Wafer DIN PN40	44						
		Wafer JPI 150	61						
		Wafer JPI 300	62						
		IV	Electrode	SUS316L	L				
Hastelloy C	C								
Titanium	K								
Zirconium	H								
Tantalum	T								
Tungsten carbide	W								
Platinum iridium	P								
Others	<input type="checkbox"/>								
V	Grounding ring	SUS316	S						
		Hastelloy C	C						
		Titanium	K						
		Zirconium	H						
		Tantalum	T						
		Platinum iridium	P						
Others	<input type="checkbox"/>								
VI	Electrical connection / watertight gland	Integral type	1						
		Remote type	G1/2 internal thread / without watertight gland	2					
			G1/2 internal thread / with brass (Ni-plated) watertight gland	3					
			G1/2 internal thread / with plastic watertight gland	4					
			1/2NPT internal thread / without watertight gland (Note 1)	5					
			CM20 internal thread / without watertight gland	6					
			Pg 13.5 internal thread / without watertight gland	7					
			G1/2 internal thread / with SUS304 watertight gland	8					
VII	Face-to-face dimensions	Standard	A						
		Others	<input type="checkbox"/>						
VIII	Installation / wiring direction	Integral type	H						
		Remote type	Upstream side (horizontal / vertical piping mounting)	A					
			Downstream side (horizontal / vertical piping mounting)	B					
			Horizontal piping mounting / left side viewed from upstream	C					
	Horizontal piping mounting / right side viewed from upstream	D							
IX	Calibration	Standard	A						
		+/- 0.35% of rate calibration (Size 40 to 200 mm (1 1/2 to 8 inches))	U						
		Others	<input type="checkbox"/>						
X	Finish	Standard	X						
		Corrosion-resistant finish	1						
		Corrosion-proof finish	2						
XI	Bolt / nut	None	X						
		Carbon steel	1						
		SUS304	2						

Options		
	Yamatake version (must be selected)	Y
	Calibration certificate (sent to ordering location separately)	A
	Traceability certificate for detector	B
	Material certificate (only for electrodes and ground rings)	C
	With gasket for plastic piping	J
	Attachment of the TAG number to the terminal box for detector (Note 2)	K
	Attachment of the TAG number plate to neck section for detector	L

Note) 1. Must be selected for CSA/FM NI approval  
 2. Must be selected for Tag no. requirement

**Flange type (15 to 200 mm (1/2 to 8 inches)) PFA / ETFE lining**

Model MGG18F - I II III IV V VI VII VIII IX X - XI - Y / Options (some options can be selected per each model)

Basic model no.		Selections				Optional selections			
MGG18F									
I	Line size	15 mm (1/2 inch)	015						
		25 mm (1 inch)	025						
		40 mm (1½ inches)	040						
		50 mm (2 inches)	050						
		65 mm (2½ inches)	065						
		80 mm (3 inches)	080						
		100 mm (4 inches)	100						
		125 mm (5 inches)	125						
		150 mm (6 inches)	150						
	200 mm (8 inches)	200							
II	Lining	ETFE (Size 80 to 200 mm (3 to 8 inches))	E						
		PFA	P						
III	Piping connection	Flange JIS 10K	J1						
		Flange JIS 20K	J2						
		Flange JIS 30K	J3						
		Flange ANSI 150	A1						
		Flange ANSI 300	A2						
		Flange JIS G3451 F12 (line size 80 mm or larger)	G1						
		Flange DIN PN10	D1						
		Flange DIN PN16	D2						
		Flange DIN PN25	D3						
		Flange DIN PN40	D4						
		Flange JPI 150	P1						
		Flange JPI 300	P2						
		IV	Flange material	Standard	I				
Others	<input type="checkbox"/>								
V	Electrode	SUS316L	L						
		Hastelloy C	C						
		Titanium	K						
		Zirconium	H						
		Tantalum	T						
		Tungsten carbide	W						
		Platinum iridium	P						
		Others	<input type="checkbox"/>						
VI	Grounding ring	SUS316	S						
		Hastelloy C	C						
		Titanium	K						
		Zirconium	H						
		Tantalum	T						
		Platinum iridium	P						
		Others	<input type="checkbox"/>						
VII	Electrical connection / watertight gland	Integral type		1					
		Remote type	G1/2 internal thread / without watertight gland		2				
			G1/2 internal thread / with brass (Ni-plated) watertight gland		3				
			G1/2 internal thread / with plastic watertight gland		4				
			1/2NPT internal thread / without watertight gland (Note 1)		5				
			CM20 internal thread / without watertight gland		6				
			Pg 13.5 internal thread / without watertight gland		7				
			G1/2 internal thread / with SUS304 watertight gland		8				
VIII	Face-to-face dimensions	Standard					A		
		Others	<input type="checkbox"/>						
IX	Installation / wiring direction	Integral type						H	
		Remote type	Upstream side (horizontal / vertical piping mounting)					A	
			Downstream side (horizontal / vertical piping mounting)					B	
			Horizontal piping mounting / left side viewed from upstream					C	
			Horizontal piping mounting / right side viewed from upstream					D	
X	Calibration	Standard						A	
		+/- 0.35% of rate calibration (Size 40 to 200 mm (1 1/2 to 8 inches))						U	
		Others	<input type="checkbox"/>						
XI	Finish	Standard						X	
		Corrosion-resistant finish						1	
		Corrosion-proof finish						2	

Options		
Yamatake version (must be selected)	Y	
Calibration certificate (sent to ordering location separately)	A	
Traceability certificate for detector	B	
Material certificate (only for electrodes and ground rings)	C	
With gasket for plastic piping	J	
Attachment of the TAG number to the terminal box for detector (Note 2)	K	
Attachment of the TAG number plate to neck section for detector	L	

Note) 1. Must be selected for CSA/FM NI approval  
 2. Must be selected for Tag no. requirement

**Flange type (250 to 600 mm (10 to 24 inches)) PFA / ETFE lining**

Model MGG18F - I II III IV V VI VII VIII IX X - XI - Y / Options (some options can be selected per each model)

Basic model no.		Selections					Optional selections					
MGG18F												
I	Line size	250 mm (10 inches)	250									
		300 mm (12 inches)	300									
		350 mm (14 inches)	350									
		400 mm (16 inches)	400									
		450 mm (18 inches)	450									
		500 mm (20 inches)	500									
II	Lining	ETFE	E									
		PFA	P									
III	Piping connection	Flange JIS 10K	J1									
		Flange JIS 20K	J2									
		Flange ANSI 150	A1									
		Flange ANSI 300 (Size 16 inches or smaller)	A2									
		Flange JIS G3451 F12	G1									
		Flange DIN PN10	D1									
		Flange DIN PN16	D2									
		Flange DIN PN25	D3									
		Flange JPI 150	P1									
IV	Flange material	Standard	1									
		Others	<input type="checkbox"/>									
V	Electrode	SUS316L	L									
		Hastelloy C	C									
		Titanium	K									
		Zirconium	H									
		Tantalum	T									
		Tungsten carbide	W									
		Platinum iridium	P									
VI	Grounding ring	SUS316	S									
		Hastelloy C	C									
		Titanium	K									
		Others	<input type="checkbox"/>									
VII	Electrical connection / watertight gland	Integral type	1									
		Remote type	G1/2 internal thread / without watertight gland	2								
			G1/2 internal thread / with brass (Ni-plated) watertight gland	3								
			G1/2 internal thread / with plastic watertight gland	4								
			1/2NPT internal thread / without watertight gland (Note 1)	5								
			CM20 internal thread / without watertight gland	6								
			Pg 13.5 internal thread / without watertight gland	7								
			G1/2 internal thread / with SUS304 watertight gland	8								
VIII	Face-to-face dimensions	Standard	A									
		Others	<input type="checkbox"/>									
IX	Installation / wiring direction	Integral type	H									
		Remote type	Upstream side (horizontal / vertical piping mounting)	A								
			Downstream side (horizontal / vertical piping mounting)	B								
			Horizontal piping mounting / left side viewed from upstream	C								
X	Calibration	Standard	A									
		+/- 0.35% of rate calibration (Size 250 to 350 mm (10 to 14 inches))	U									
		Others	<input type="checkbox"/>									
XI	Finish	Standard	X									
		Corrosion-resistant finish	1									
		Corrosion-proof finish	2									

Options		
Yamatake version (must be selected)	Y	
Calibration certificate (sent to ordering location separately)	A	
Traceability certificate for detector	B	
Material certificate (only for electrodes and ground rings)	C	
With gasket for plastic piping	J	
Attachment of the TAG number to the terminal box for detector (Note 2)	K	
Attachment of the TAG number plate to neck section for detector	L	

Note) 1. Must be selected for CSA/FM NI approval.  
2. Must be selected for Tag no. requirement.

**Wafer type (25 to 200 mm (1 to 8 inches)) Polyurethane rubber lining**

Model MGG18D - I II III IV V VI VII VIII IX - X XI - Y / Options (some options can be selected per each model)

Basic model no.		Selections				Optional selections				
MGG18D										
I	Line size	25 mm (1 inch)	025							
		40 mm (1½ inches)	040							
		50 mm (2 inches)	050							
		65 mm (2½ inches)	065							
		80 mm (3 inches)	080							
		100 mm (4 inches)	100							
		125 mm (5 inches)	125							
		150 mm (6 inches)	150							
	200 mm (8 inches)	200								
II	Lining	Polyurethane rubber			Q					
III	Piping connection	Wafer JIS 10K		11						
		Wafer JIS 20K		12						
		Wafer JIS 30K		13						
		Wafer ANSI 150		21						
		Wafer ANSI 300		22						
		Wafer JIS G3451 F12 (line size 80 mm or larger)		31						
		Wafer DIN PN10		41						
		Wafer DIN PN16		42						
		Wafer DIN PN25		43						
		Wafer DIN PN40		44						
		Wafer JPI 150		61						
		Wafer JPI 300		62						
IV	Electrode	SUS316L			L					
		Titanium			K					
		Tungsten carbide (only for size 10 mm)			W					
		Others			<input type="checkbox"/>					
V	Grounding ring	SUS316			S					
		Titanium			K					
		Others			<input type="checkbox"/>					
VI	Electrical connection / watertight gland	Integral type				1				
		Remote type	G1/2 internal thread / without watertight gland				2			
			G1/2 internal thread / with brass (Ni-plated) watertight gland				3			
			G1/2 internal thread / with plastic watertight gland				4			
			1/2NPT internal thread / without watertight gland (Note 1)				5			
			CM20 internal thread / without watertight gland				6			
			Pg 13.5 internal thread / without watertight gland				7			
			G1/2 internal thread / with SUS304 watertight gland				8			
VII	Face-to-face dimensions	Standard					A			
VIII	Installation / wiring direction	Integral type					H			
		Remote type	Upstream side (horizontal / vertical piping mounting)					A		
			Downstream side (horizontal / vertical piping mounting)					B		
			Horizontal piping mounting / left side viewed from upstream					C		
			Horizontal piping mounting / right side viewed from upstream					D		
IX	Calibration	Standard						A		
		+/- 0.35% of rate calibration (Size 40 to 200 mm (1 1/2 to 8 inches))							U	
		Others							<input type="checkbox"/>	
X	Finish	Standard							X	
		Corrosion-resistant finish								1
		Corrosion-proof finish								2
XI	Bolt / nut	None							X	
		Carbon steel								1
		SUS304								2

Options		
	Yamatake version (must be selected)	Y
	Calibration certificate (sent to ordering location separately)	A
	Traceability certificate for detector	B
	Material certificate (only for electrodes and ground rings)	C
	With gasket for plastic piping	J
	Attachment of the TAG number to the terminal box for detector (Note 2)	K
	Attachment of the TAG number plate to neck section for detector	L

Note) 1. Must be selected for CSA/FM NI approval  
 2. Must be selected for Tag no. requirement

**Flange type (25 to 200 mm (1 to 8 inches)) Polyurethane rubber lining**

Model MGG18F - I II III IV V VI VII VIII IX X - XI - Y / Options (some options can be selected per each model)

Basic model no.		Selections					Optional selections					
MGG18F												
I	Line size	25 mm (1 inch)	025									
		40 mm (1½ inches)	040									
		50 mm (2 inches)	050									
		65 mm (2½ inches)	065									
		80 mm (3 inches)	080									
		100 mm (4 inches)	100									
		125 mm (5 inches)	125									
		150 mm (6 inches)	150									
		200 mm (8 inches)	200									
II	Lining	Polyurethane rubber					Q					
III	Piping connection	Flange JIS 10K					J1					
		Flange JIS 20K					J2					
		Flange JIS 30K					J3					
		Flange ANSI 150					A1					
		Flange ANSI 300					A2					
		Flange JIS G3451 F12 (line size 80 mm or larger)					G1					
		Flange DIN PN10					D1					
		Flange DIN PN16					D2					
		Flange DIN PN25					D3					
		Flange DIN PN40					D4					
		Flange JPI 150					P1					
		Flange JPI 300					P2					
		IV	Flange material	Standard					1			
Others					<input type="checkbox"/>							
V	Electrode	SUS316L					L					
		Titanium					K					
		Tungsten carbide (only for size 10 mm)					W					
		Others					<input type="checkbox"/>					
VI	Grounding ring	SUS316					S					
		Titanium					K					
		Others					<input type="checkbox"/>					
VII	Electrical connection / watertight gland	Integral type					1					
		Remote type	G1/2 internal thread / without watertight gland					2				
			G1/2 internal thread / with brass (Ni-plated) watertight gland					3				
			G1/2 internal thread / with plastic watertight gland					4				
			1/2NPT internal thread / without watertight gland (Note 1)					5				
			CM20 internal thread / without watertight gland					6				
			Pg 13.5 internal thread / without watertight gland					7				
			G1/2 internal thread / with SUS304 watertight gland					8				
VIII	Face-to-face dimensions	Standard					A					
IX	Installation / wiring direction	Integral type					H					
		Remote type	Upstream side (horizontal / vertical piping mounting)					A				
			Downstream side (horizontal / vertical piping mounting)					B				
			Horizontal piping mounting / left side viewed from upstream					C				
			Horizontal piping mounting / right side viewed from upstream					D				
X	Calibration	Standard					A					
		+/- 0.35% of rate calibration (Size 40 to 200 mm (1 1/2 to 8 inches))					U					
		Others					<input type="checkbox"/>					
XI	Finish	Standard					X					
		Corrosion-resistant finish					1					
		Corrosion-proof finish					2					

Options		
Yamatake version (must be selected)	Y	
Calibration certificate (sent to ordering location separately)	A	
Traceability certificate for detector	B	
Material certificate (only for electrodes and ground rings)	C	
With gasket for plastic piping	J	
Attachment of the TAG number to the terminal box for detector (Note 2)	K	
Attachment of the TAG number plate to neck section for detector	L	

Note) 1. Must be selected for CSA/FM NI approval  
 2. Must be selected for Tag no. requirement

**Flange type (250 to 600 mm (10 to 24 inches)) Chloroprene rubber lining**

Model MGG18F - I II III IV V VI VII VIII IX X - XI - Y / Options (some options can be selected per each model)

Basic model no.		Selections				Optional selections			
MGG18F									
I	Line size	250 mm (10 inches)	250						
		300 mm (12 inches)	300						
		350 mm (14 inches)	350						
		400 mm (16 inches)	400						
		450 mm (18 inches)	450						
		500 mm (20 inches)	500						
		600 mm (24 inches)	600						
II	Lining	Chloroprene rubber		R					
III	Piping connection	Flange JIS 10K		J1					
		Flange ANSI 150		A1					
		Flange JIS G3451 F12		G1					
		Flange DIN PN10		D1					
		Flange JPI 150		P1					
IV	Flange material	Standard		1					
		Others		<input type="checkbox"/>					
V	Electrode	SUS316L		L					
		Titanium		K					
		Tungsten carbide		W					
		Others		<input type="checkbox"/>					
VI	Grounding ring	SUS316		S					
		Titanium		K					
		Others		<input type="checkbox"/>					
VII	Electrical connection / watertight gland	Integral type			1				
		Remote type	G1/2 internal thread / without watertight gland		2				
			G1/2 internal thread / with brass (Ni-plated) watertight gland		3				
			G1/2 internal thread / with plastic watertight gland		4				
			1/2NPT internal thread / without watertight gland (Note 1)		5				
			CM20 internal thread / without watertight gland		6				
			Pg 13.5 internal thread / without watertight gland		7				
			G1/2 internal thread / with SUS304 watertight gland		8				
VIII	Face-to-face dimensions	Standard			A				
		Others		<input type="checkbox"/>					
IX	Installation / wiring direction	Integral type			H				
		Remote type	Upstream side (horizontal / vertical piping mounting)		A				
			Downstream side (horizontal / vertical piping mounting)		B				
			Horizontal piping mounting / left side viewed from upstream		C				
			Horizontal piping mounting / right side viewed from upstream		D				
X	Calibration	Standard			A				
		+/- 0.35% of rate calibration (Size 250 to 350 mm (10 to 14 inches))			U				
		Others		<input type="checkbox"/>					
XI	Finish	Standard			X				
		Corrosion-resistant finish			1				
		Corrosion-proof finish			2				

Options		
	Yamatake version (must be selected)	Y
	Calibration certificate (sent to ordering location separately)	A
	Traceability certificate for detector	B
	Material certificate (only for electrodes and ground rings)	C
	With gasket for plastic piping	J
	Attachment of the TAG number to the terminal box for detector (Note 2)	K
	Attachment of the TAG number plate to neck section for detector	L

Note) 1. Must be selected for CSA/FM NI approval  
 2. Must be selected for Tag no. requirement

**Flange type (700 to 1100 mm (28 to 44 inches)) Chloroprene rubber lining**

Model MGG18F - I II III IV V VI VII VIII IX X - XI - Y / Options (some options can be selected per each model)

Basic model no.		Selections				Optional selections				
MGG18F										
I	Line size	700 mm (28 inches)	700							
		800 mm (32 inches)	800							
		900 mm (36 inches)	900							
		1000 mm (40 inches)	10H							
		1100 mm (44 inches)	11H							
II	Lining	Chloroprene rubber	R							
III	Piping connection	Flange JIS 10K	J1							
		Flange ANSI 150	A1							
		Flange JIS G3451 F12	G1							
		Flange DIN PN10	D1							
		Flange JPI 150	P1							
IV	Flange material	Standard	1							
V	Electrode	SUS316L	L							
		Titanium	K							
		Tungsten carbide	W							
		Others	<input type="checkbox"/>							
VI	Grounding ring	SUS316	S							
		Others	<input type="checkbox"/>							
VII	Electrical connection / watertight gland	Integral type	1							
		Remote type	G1/2 internal thread / without watertight gland	2						
			G1/2 internal thread / with brass (Ni-plated) watertight gland	3						
			G1/2 internal thread / with plastic watertight gland	4						
			1/2NPT internal thread / without watertight gland	5						
			CM20 internal thread / without watertight gland	6						
			Pg 13.5 internal thread / without watertight gland	7						
			G1/2 internal thread / with SUS304 watertight gland	8						
VIII	Face-to-face dimensions	Standard	A							
		Others	<input type="checkbox"/>							
IX	Installation / wiring direction	Integral type	H							
		Remote type	Upstream side (horizontal / vertical piping mounting)	A						
			Downstream side (horizontal / vertical piping mounting)	B						
			Horizontal piping mounting / left side viewed from upstream	C						
			Horizontal piping mounting / right side viewed from upstream	D						
X	Calibration	Standard	A							
		Others	<input type="checkbox"/>							
XI	Finish	Standard	X							
		Corrosion-resistant finish	1							
		Corrosion-proof finish	2							

Options		
Yamatake version (must be selected)	Y	
Calibration certificate (sent to ordering location separately)	A	
Traceability certificate for detector	B	
Material certificate (only for electrodes and ground rings)	C	
Attachment of the TAG number to the terminal box for detector (Note 1)	K	
Attachment of the TAG number plate to neck section for detector	L	

Note) 1. Must be selected for Tag no. requirement

**Submersible detector with FM/CSA NI approval**  
**Wafer type (15 to 200 mm (1/2 to 8 inches)) PFA / ETFE lining**

Model MGG19D - I II III IV V VI VII VIII IX - X XI - Y / Options (some options can be selected per each model)

Basic model no.		Selections				Optional selections			
MGG19D									
I	Line size	15 mm (1/2 inch)	015						
		25 mm (1 inch)	025						
		40 mm (1½ inches)	040						
		50 mm (2 inches)	050						
		65 mm (2½ inches)	065						
		80 mm (3 inches)	080						
		100 mm (4 inches)	100						
		125 mm (5 inches)	125						
		150 mm (6 inches)	150						
	200 mm (8 inches)	200							
II	Lining	ETFE (Size 80 to 200 mm (3 to 8 inches))	E						
		PFA	P						
III	Piping connection	Wafer JIS 10K		11					
		Wafer JIS 20K		12					
		Wafer JIS 30K		13					
		Wafer ANSI 150		21					
		Wafer ANSI 300		22					
		Wafer JIS G3451 F12 (line size 80 mm or larger)		31					
		Wafer DIN PN10		41					
		Wafer DIN PN16		42					
		Wafer DIN PN25		43					
		Wafer DIN PN40		44					
		Wafer JPI 150		61					
		Wafer JPI 300		62					
IV	Electrode	SUS316L		L					
		Hastelloy C		C					
		Titanium		K					
		Zirconium		H					
		Tantalum		T					
		Tungsten carbide		W					
		Platinum iridium		P					
		Others		<input type="checkbox"/>					
V	Grounding ring	SUS316		S					
		Hastelloy C		C					
		Titanium		K					
		Zirconium		H					
		Tantalum		T					
		Platinum iridium		P					
		Others		<input type="checkbox"/>					
VI	Electrical connection / watertight gland	Remote type	G1/2 internal thread / with brass (Ni-plated) watertight gland		3				
			G1/2 internal thread / with SUS304 watertight gland		8				
VII	Face-to-face dimensions	Standard				A			
		Others				<input type="checkbox"/>			
VIII	Installation / wiring direction	Remote type	Upstream side (horizontal / vertical piping mounting)			A			
			Downstream side (horizontal / vertical piping mounting)			B			
			Horizontal piping mounting / left side viewed from upstream			C			
			Horizontal piping mounting / right side viewed from upstream			D			
IX	Calibration	Standard				A			
		+/- 0.35% of rate calibration (Size 40 to 200 mm (1 1/2 to 8 inches))				U			
		Others				<input type="checkbox"/>			
X	Finish	Standard					X		
XI	Bolt / nut	None					X		
		Carbon steel					1		
		SUS304					2		

Options		
Yamatake version (must be selected)	Y	
Calibration certificate (sent to ordering location separately)	A	
Traceability certificate for detector	B	
Material certificate (only for electrodes and ground rings)	C	
With gasket for plastic piping	J	
Attachment of the TAG number to the terminal box for detector (Note 1)	K	
Attachment of the TAG number plate to neck section for detector	L	

Note) 1. Must be selected for Tag no. requirement

**Submersible detector with FM/CSA NI approval**  
**Flange type (15 to 200 mm (1/2 to 8 inches)) PFA / ETFE lining**

Model MGG19F - I II III IV V VI VII VIII IX X - XI - Y / Options (some options can be selected per each model)

Basic model no.		MGG19F		Selections				Optional selections					
I	Line size	15 mm (1/2 inch)	015										
		25 mm (1 inch)	025										
		40 mm (1½ inches)	040										
		50 mm (2 inches)	050										
		65 mm (2½ inches)	065										
		80 mm (3 inches)	080										
		100 mm (4 inches)	100										
		125 mm (5 inches)	125										
		150 mm (6 inches)	150										
		200 mm (8 inches)	200										
II	Lining	ETFE (Size 80 to 200 mm (3 to 8 inches))		E									
		PFA		P									
III	Piping connection	Flange JIS 10K		J1									
		Flange JIS 20K		J2									
		Flange JIS 30K		J3									
		Flange ANSI 150		A1									
		Flange ANSI 300		A2									
		Flange JIS G3451 F12 (line size 80 mm or larger)		G1									
		Flange DIN PN10		D1									
		Flange DIN PN16		D2									
		Flange DIN PN25		D3									
		Flange DIN PN40		D4									
		Flange JPI 150		P1									
		Flange JPI 300		P2									
		IV	Flange material	Standard		1							
				Others		<input type="checkbox"/>							
V	Electrode	SUS316L		L									
		Hastelloy C		C									
		Titanium		K									
		Zirconium		H									
		Tantalum		T									
		Tungsten carbide		W									
		Platinum iridium		P									
		Others		<input type="checkbox"/>									
VI	Grounding ring	SUS316		S									
		Hastelloy C		C									
		Titanium		K									
		Zirconium		H									
		Tantalum		T									
		Platinum iridium		P									
		Others		<input type="checkbox"/>									
VII	Electrical connection / watertight gland	Remote type	G1/2 internal thread / with brass (Ni-plated) watertight gland	3									
			G1/2 internal thread / with SUS304 watertight gland	8									
VIII	Face-to-face dimensions	Standard		A									
		Others		<input type="checkbox"/>									
IX	Installation / wiring direction	Remote type	Upstream side (horizontal / vertical piping mounting)		A								
			Downstream side (horizontal / vertical piping mounting)		B								
			Horizontal piping mounting / left side viewed from upstream		C								
			Horizontal piping mounting / right side viewed from upstream		D								
X	Calibration	Standard		A									
		+/- 0.35% of rate calibration (Size 40 to 200 mm (1 1/2 to 8 inches))		U									
		Others		<input type="checkbox"/>									
XI	Finish	Standard								X			

Options		
	Yamatake version (must be selected)	Y
	Calibration certificate (sent to ordering location separately)	A
	Traceability certificate for detector	B
	Material certificate (only for electrodes and ground rings)	C
	With gasket for plastic piping	J
	Attachment of the TAG number to the terminal box for detector (Note 1)	K
	Attachment of the TAG number plate to neck section for detector	L

Note) 1. Must be selected for Tag no. requirement

Submersible detector with FM/CSA NI approval

Flange type (250 to 600 mm (10 to 24 inches)) PFA / ETFE lining

Model MGG19F - I II III IV V VI VII VIII IX X - XI - Y / Options (some options can be selected per each model)

Basic model no.		Selections				Optional selections				
MGG19F										
I	Line size	250 mm (10 inches)	250							
		300 mm (12 inches)	300							
		350 mm (14 inches)	350							
		400 mm (16 inches)	400							
		450 mm (18 inches)	450							
		500 mm (20 inches)	500							
		600 mm (24 inches)	600							
II	Lining	ETFE	E							
		PFA	P							
III	Piping connection	Flange JIS 10K	J1							
		Flange JIS 20K	J2							
		Flange ANSI 150	A1							
		Flange ANSI 300 (Size 16 inches or smaller)	A2							
		Flange JIS G3451 F12	G1							
		Flange DIN PN10	D1							
		Flange DIN PN16	D2							
		Flange DIN PN25	D3							
		Flange JPI 150	P1							
		Flange JPI 300 (Size 400 mm or smaller)	P2							
IV	Flange material	Standard	1							
		Others	<input type="checkbox"/>							
V	Electrode	SUS316L	L							
		Hastelloy C	C							
		Titanium	K							
		Zirconium	H							
		Tantalum	T							
		Tungsten carbide	W							
		Platinum iridium	P							
		Others	<input type="checkbox"/>							
VI	Grounding ring	SUS316	S							
		Hastelloy C	C							
		Titanium	K							
		Others	<input type="checkbox"/>							
VII	Electrical connection / watertight gland	Remote type	G1/2 internal thread / with brass (Ni-plated) watertight gland	3						
			G1/2 internal thread / with SUS304 watertight gland	8						
VIII	Face-to-face dimensions	Standard	A							
		Others	<input type="checkbox"/>							
IX	Installation / wiring direction	Remote type	Upstream side (horizontal / vertical piping mounting)							
			Downstream side (horizontal / vertical piping mounting)							B
			Horizontal piping mounting / left side viewed from upstream							C
			Horizontal piping mounting / right side viewed from upstream							D
X	Calibration	Standard	A							
		+/- 0.35% of rate calibration (Size 250 to 350 mm (10 to 14 inches))		U						
		Others		<input type="checkbox"/>						
XI	Finish	Standard							X	

Options		
Yamatake version (must be selected)	Y	
Calibration certificate (sent to ordering location separately)	A	
Traceability certificate for detector	B	
Material certificate (only for electrodes and ground rings)	C	
With gasket for plastic piping	J	
Attachment of the TAG number to the terminal box for detector (Note 1)	K	
Attachment of the TAG number plate to neck section for detector	L	

Note) 1. Must be selected for Tag no. requirement

**Submersible detector with FM/CSA NI approval**  
**Wafer type (25 to 200 mm (1 to 8 inches)) Polyurethane rubber lining**

Model MGG19D - I II III IV V VI VII VIII IX - X XI - Y / Options (some options can be selected per each model)

Basic model no.		Selections				Optional selections					
MGG19D											
I	Line size	25 mm (1 inch)	025								
		40 mm (1½ inches)	040								
		50 mm (2 inches)	050								
		65 mm (2½ inches)	065								
		80 mm (3 inches)	080								
		100 mm (4 inches)	100								
		125 mm (5 inches)	125								
		150 mm (6 inches)	150								
		200 mm (8 inches)	200								
II	Lining	Polyurethane rubber			Q						
III	Piping connection	Wafer JIS 10K	11								
		Wafer JIS 20K	12								
		Wafer JIS 30K	13								
		Wafer ANSI 150	21								
		Wafer ANSI 300	22								
		Wafer JIS G3451 F12 (line size 80 mm or larger)	31								
		Wafer DIN PN10	41								
		Wafer DIN PN16	42								
		Wafer DIN PN25	43								
		Wafer DIN PN40	44								
		Wafer JPI 150	61								
		Wafer JPI 300	62								
		IV	Electrode	SUS316L	L						
				Titanium	K						
Tungsten carbide (only for size 10 mm)	W										
Others	<input type="checkbox"/>										
V	Grounding ring	SUS316	S								
		Titanium	K								
		Others	<input type="checkbox"/>								
VI	Electrical connection / watertight gland	Remote type	G1/2 internal thread / with brass (Ni-plated) watertight gland	3							
			G1/2 internal thread / with SUS304 watertight gland	8							
VII	Face-to-face dimensions	Standard			A						
VIII	Installation / wiring direction	Remote type	Upstream side (horizontal / vertical piping mounting)			A					
			Downstream side (horizontal / vertical piping mounting)			B					
			Horizontal piping mounting / left side viewed from upstream			C					
			Horizontal piping mounting / right side viewed from upstream			D					
IX	Calibration	Standard			A						
		+/- 0.35% of rate calibration (Size 40 to 200 mm (1 1/2 to 8 inches))			U						
		Others			<input type="checkbox"/>						
X	Finish	Standard							X		
XI	Bolt / nut	None							X		
		Carbon steel							1		
		SUS304							2		

Options		
	Yamatake version (must be selected)	Y
	Calibration certificate (sent to ordering location separately)	A
	Traceability certificate for detector	B
	Material certificate (only for electrodes and ground rings)	C
	With gasket for plastic piping	J
	Attachment of the TAG number to the terminal box for detector (Note 1)	K
	Attachment of the TAG number plate to neck section for detector	L

Note) 1. Must be selected for Tag no. requirement

**Submersible detector with FM/CSA NI approval**  
**Flange type (25 to 200 mm (1 to 8 inches)) Polyurethane rubber lining**

Model MGG19F - I II III IV V VI VII VIII IX X - XI - Y / Options (some options can be selected per each model)

Basic model no.		MGG19F		-		Selections		Optional selections		-		-	
I	Line size	25 mm (1 inch)	025										
		40 mm (1½ inches)	040										
		50 mm (2 inches)	050										
		65 mm (2½ inches)	065										
		80 mm (3 inches)	080										
		100 mm (4 inches)	100										
		125 mm (5 inches)	125										
		150 mm (6 inches)	150										
		200 mm (8 inches)	200										
II	Lining	Polyurethane rubber		Q									
III	Piping connection	Flange JIS 10K		J1									
		Flange JIS 20K		J2									
		Flange JIS 30K		J3									
		Flange ANSI 150		A1									
		Flange ANSI 300		A2									
		Flange JIS G3451 F12 (line size 80 mm or larger)		G1									
		Flange DIN PN10		D1									
		Flange DIN PN16		D2									
		Flange DIN PN25		D3									
		Flange DIN PN40		D4									
		Flange JPI 150		P1									
		Flange JPI 300		P2									
		IV	Flange material	Standard									
V	Electrode	SUS316L		L									
		Titanium		K									
		Tungsten carbide		W									
		Others		<input type="checkbox"/>									
VI	Grounding ring	SUS316		S									
		Titanium		K									
		Others		<input type="checkbox"/>									
VII	Electrical connection / watertight gland	Remote type	G1/2 internal thread / with brass (Ni-plated) watertight gland		3								
			G1/2 internal thread / with SUS304 watertight gland		8								
VIII	Face-to-face dimensions	Standard		A									
IX	Installation / wiring direction	Remote type	Upstream side (horizontal / vertical piping mounting)		A								
			Downstream side (horizontal / vertical piping mounting)		B								
			Horizontal piping mounting / left side viewed from upstream		C								
			Horizontal piping mounting / right side viewed from upstream		D								
X	Calibration	Standard		A									
		+/- 0.35% of rate calibration (Size 40 to 200 mm (1 1/2 to 8 inches))		U									
		Others		<input type="checkbox"/>									
XI	Finish	Standard		X									

Options		
	Yamatake version (must be selected)	Y
	Calibration certificate (sent to ordering location separately)	A
	Traceability certificate for detector	B
	Material certificate (only for electrodes and ground rings)	C
	With gasket for plastic piping	J
	Attachment of the TAG number to the terminal box for detector (Note 1)	K
	Attachment of the TAG number plate to neck section for detector	L

Note) 1. Must be selected for Tag no. requirement

**DIMENSIONS**

All dimensions are in millimeters, dimensions in brackets ( ) are in inches (inch).

**Union joint (size 2.5 to 15 mm (0.1 to 1/2 inch))**

**Terminal connection table**

Symbol	Description
X	Excitation current input
Y	
A	Flow rate signal output
B	
C	

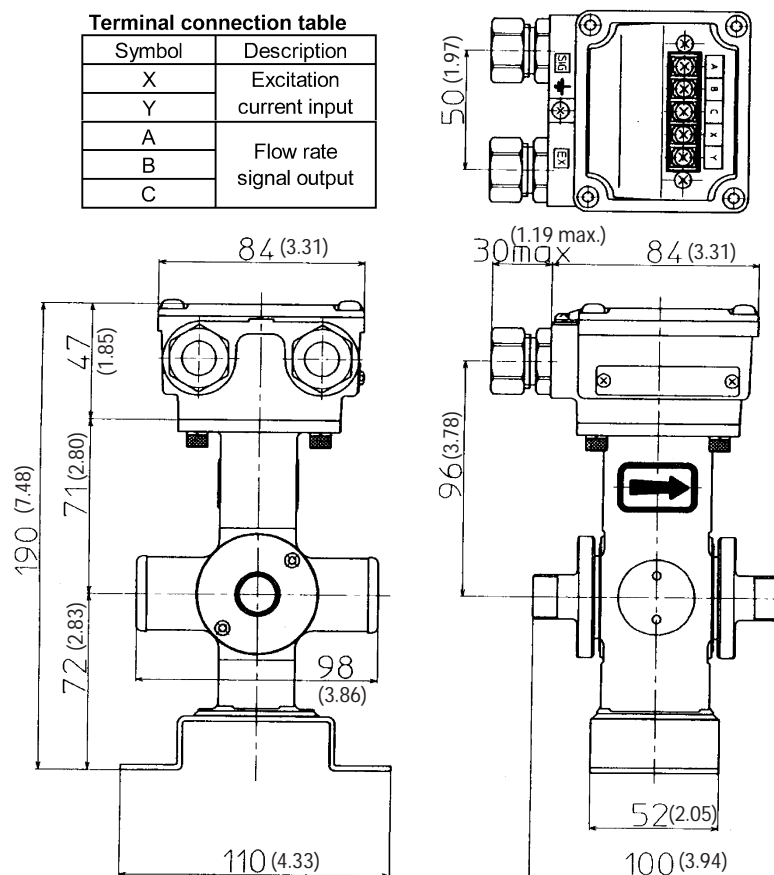

**Hose joint (size 2.5 to 15 mm (0.1 to 1/2 inch))**

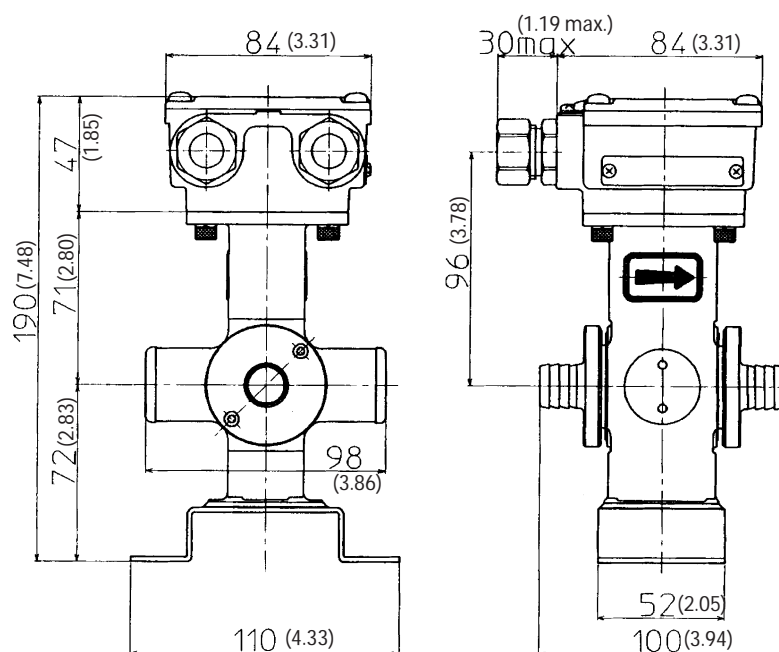

IDF / Tri clamp (size 2.5 to 15 mm (0.1 to 1/2 inch))

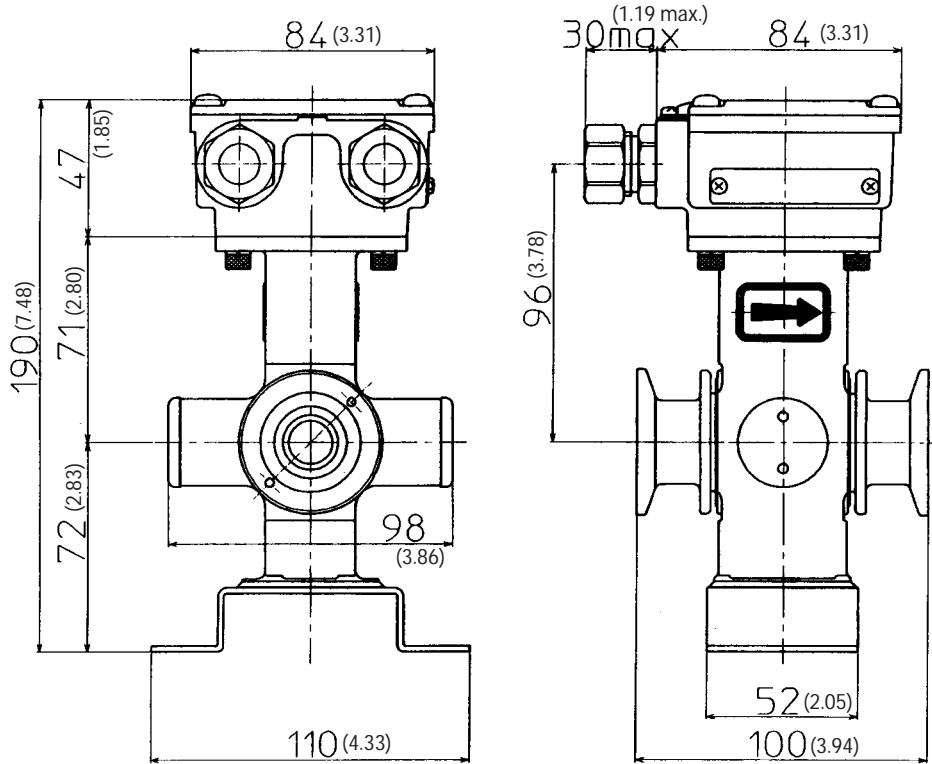

- Note) 1. An integral detector includes an integral converter instead of a terminal box.  
 2. Clamp size: IS

Wafer type (size 2.5 to 15 mm (0.1 to 1/2 inch))

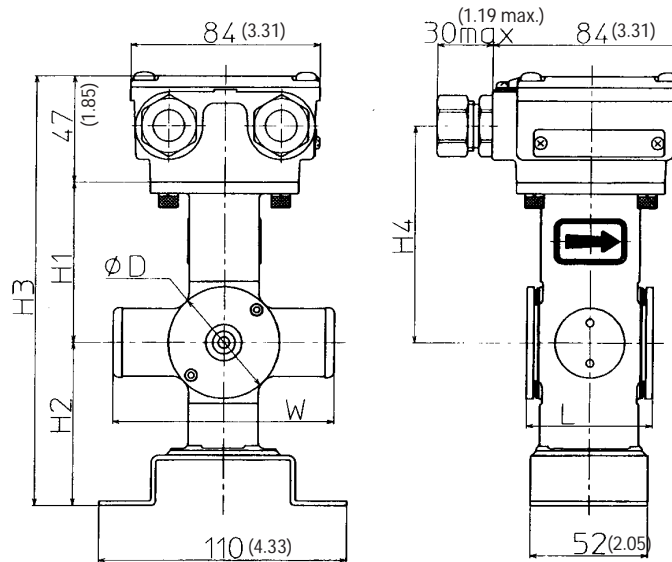

Wafer type (size 25 to 200 mm (1 to 8 inches))

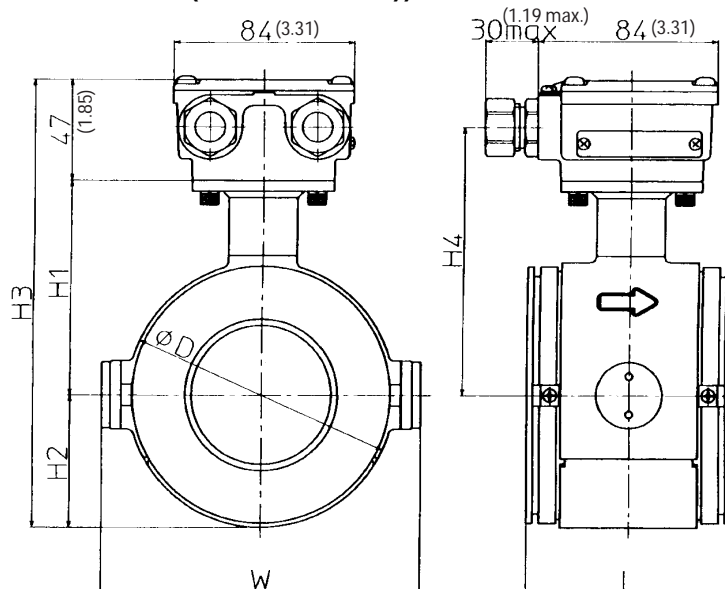

Size		mm	2.5	5	10	15	25	40	50	65	80	100	125	150	200
		(inches)	(0.1)	(0.2)	(3/8)	(1/2)	(1)	(1½)	(2)	(2½)	(3)	(4)	(5)	(6)	(8)
Face to face dimension	L	mm	56	56	56	56	56	80	86	96	106	120	140	160	200
		(inches)	(2.20)	(2.20)	(2.20)	(2.20)	(2.20)	(2.20)	(3.15)	(3.39)	(3.78)	(4.17)	(4.72)	(5.51)	(6.30)
Height	H1	mm	71	71	71	71	77	84	93	100	108	121	133	160	185
		(inches)	(2.80)	(2.80)	(2.80)	(2.80)	(3.03)	(3.31)	(3.66)	(3.94)	(4.25)	(4.76)	(5.24)	(6.30)	(7.28)
	H2	mm	72	72	72	72	34	43.5	52	62	67	79.5	95	110	135
		(inches)	(2.83)	(2.83)	(2.83)	(2.83)	(1.34)	(1.71)	(2.05)	(2.44)	(2.64)	(3.13)	(3.74)	(4.33)	(5.31)
	H3	mm	190	190	190	190	158	175	192	209	222	247	275	317	367
		(inches)	(7.48)	(7.48)	(7.48)	(7.48)	(6.22)	(6.89)	(7.56)	(8.23)	(8.74)	(9.72)	(10.83)	(12.48)	(14.45)
H4	mm	96	96	96	96	102	109	118	125	133	146	158	185	210	
	(inches)	(3.78)	(3.78)	(3.78)	(3.78)	(4.02)	(4.29)	(4.65)	(4.92)	(5.24)	(5.75)	(6.22)	(7.28)	(8.27)	
Housing width	W	mm	98	98	98	98	106	125	135	148	164	189	214	240	290
		(inches)	(3.86)	(3.86)	(3.86)	(3.86)	(4.17)	(4.92)	(5.31)	(5.83)	(6.46)	(7.44)	(8.43)	(9.45)	(11.42)
Housing outer diameter	ØD	mm	49.5	49.5	49.5	49.5	68	87	104	124	134	159	190	220	270
		(inches)	(1.95)	(1.95)	(1.95)	(1.95)	(2.68)	(3.43)	(4.09)	(4.88)	(5.28)	(6.26)	(7.48)	(8.66)	(10.63)
Weight		kg	2.6	2.6	2.6	2.3	2.6	2.8	3.4	4.5	5.2	6.7	10.0	13.6	22.0
		(lb)	(5.7)	(5.7)	(5.7)	(5.1)	(5.7)	(6.2)	(7.5)	(9.9)	(11.5)	(14.8)	(22.0)	(30.0)	(48.5)

Note) 1. An integral detector includes an integral converter instead of a terminal box.

Flange type (size 2.5 to 15 mm (0.1 to 1/2 inch))

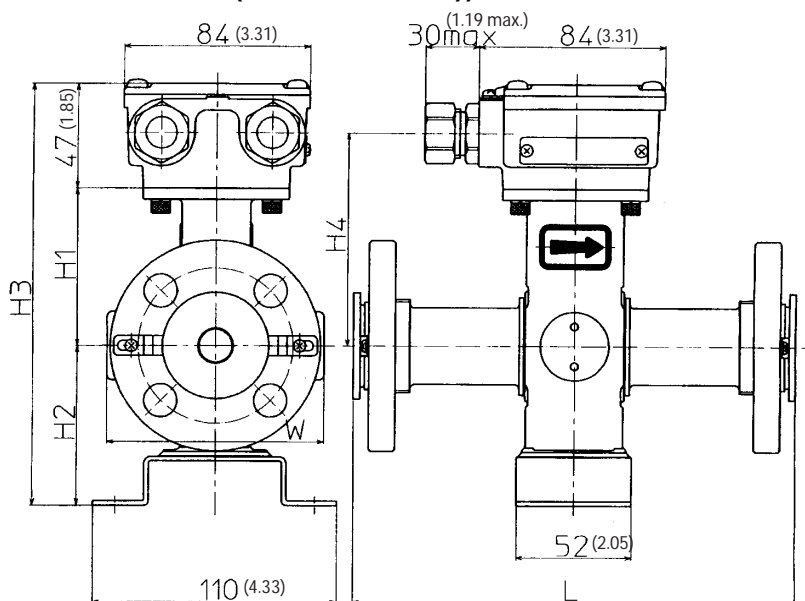

Flange type (size 25 mm (1 inch))

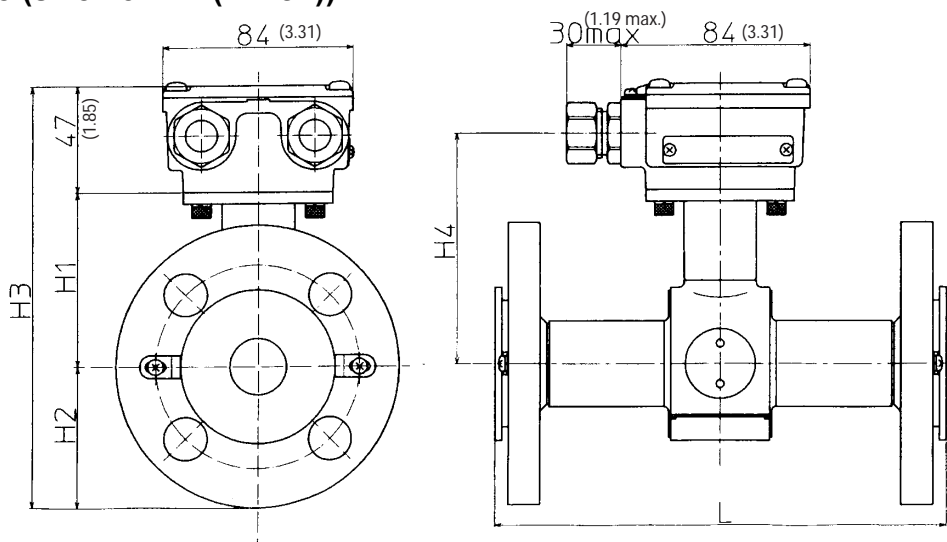

Size		mm	2.5	5	10	15	25
		(inches)	(0.1)	(0.2)	(3/8)	(1/2)	(1)
Face to face dimension	L	mm	160	160	160	200	200
		(inches)	(6.30)	(6.30)	(6.30)	(7.87)	(7.87)
Height	H1	mm	71	71	71	71	77
		(inches)	(2.80)	(2.80)	(2.80)	(2.80)	(3.03)
	H2	mm	72	72	72	72	54
		(inches)	(2.83)	(2.83)	(2.83)	(2.83)	(2.13)
	H3	mm	190	190	190	190	178
		(inches)	(7.48)	(7.48)	(7.48)	(7.48)	(7.01)
H4	mm	96	96	96	96	102	
	(inches)	(3.78)	(3.78)	(3.78)	(3.78)	(4.02)	
Width	W	mm	98	98	98	98	106
		(inches)	(3.86)	(3.86)	(3.86)	(3.86)	(4.17)
Weight			kg	5.0	5.0	5.0	5.0
			(lb)	(11.0)	(11.0)	(11.0)	(11.0)

Note) 1. This table is for remote detectors.  
 2. An integral detector includes an integral converter instead of a terminal box.  
 3. The table indicates dimensions for ANSI 150 flange.

Flange type (size 40 to 100 mm (1½ to 4 inches))

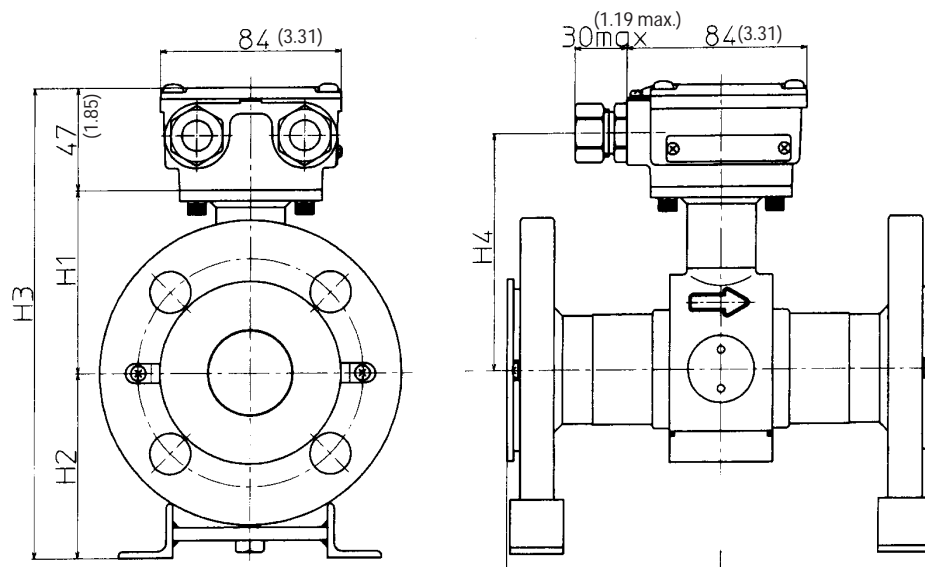

Flange type (size 150 to 600 mm (6 to 24 inches))

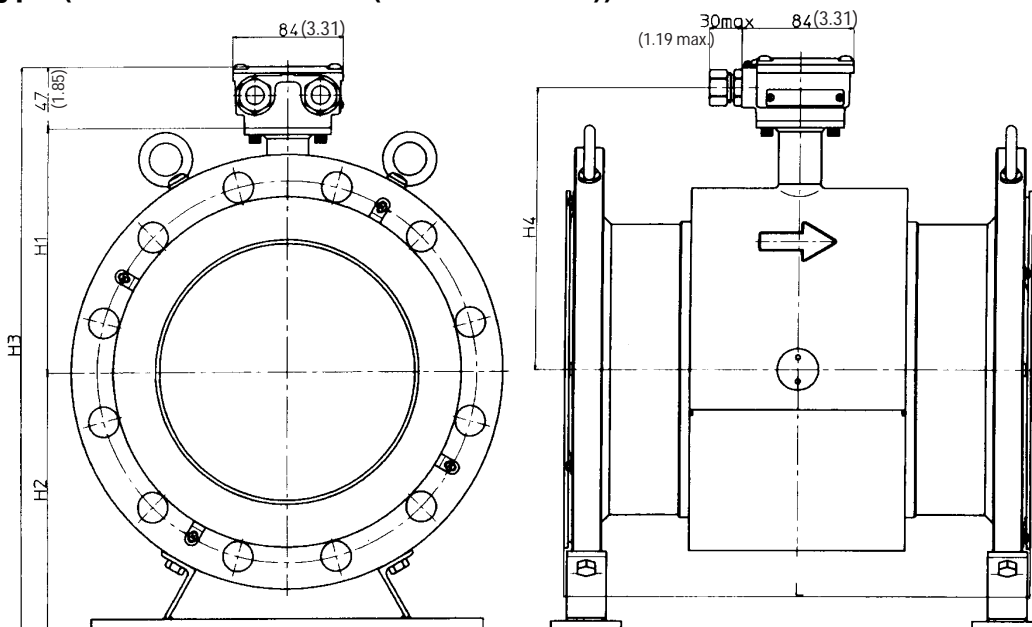

Size	mm		40	50	65	80	100	125	150	200	250	300	350	400	450	500	600
	(inches)		(1½)	(2)	(2½)	(3)	(4)	(5)	(6)	(8)	(10)	(12)	(14)	(16)	(18)	(20)	(24)
Face to face dimension	L	mm	200	200	200	200	250	250	300	350	450	500	550	600	600	600	650
		(inches)	(7.87)	(7.87)	(7.87)	(7.87)	(9.84)	(9.84)	(11.81)	(13.78)	(17.72)	(19.69)	(21.65)	(23.62)	(23.62)	(23.62)	(25.59)
Height	H1	mm	84	93	100	108	121	133	160	185	235	258	282	310	339	366	415
		(inches)	(3.31)	(3.66)	(3.94)	(4.25)	(4.76)	(5.24)	(6.30)	(7.28)	(9.25)	(10.16)	(11.10)	(12.20)	(13.35)	(14.41)	(16.34)
	H2	mm	77	88	103	113	131	145	174	204	224	271	297	340	364	396	456
		(inches)	(3.03)	(3.46)	(4.06)	(4.45)	(5.16)	(5.71)	(6.85)	(8.03)	(8.82)	(10.67)	(11.09)	(13.39)	(14.33)	(15.59)	(17.95)
	H3	mm	208	228	250	268	299	325	381	436	506	576	626	697	750	809	918
		(inches)	(8.19)	(8.98)	(9.84)	(10.55)	(11.77)	(12.80)	(15.0)	(17.17)	(19.92)	(22.68)	(24.65)	(27.44)	(29.53)	(31.85)	(36.14)
	H4	mm	109	118	125	133	146	158	185	210	260	283	307	335	364	391	440
		(inches)	(4.29)	(4.65)	(4.92)	(5.24)	(5.75)	(6.22)	(7.28)	(8.27)	(10.24)	(11.14)	(12.09)	(13.19)	(14.33)	(15.39)	(17.32)
Weight (kg)	kg	6.0	10.5	12.5	15.5	23.3	32.0	35.4	60.0	68.0	97.0	128	163	213	249	339	
	(lb)	(13.2)	(23.1)	(27.6)	(34.2)	(51.4)	(70.5)	(78.0)	(132)	(150)	(214)	(282)	(359)	(470)	(549)	(747)	

- Note) 1. This table is for remote detectors.  
 2. An integral detector includes an integral converter instead of a terminal box.  
 3. The table indicates dimensions for ANSI 150 flange.

Flange type (size 700 to 900 mm (28 to 36 inches))

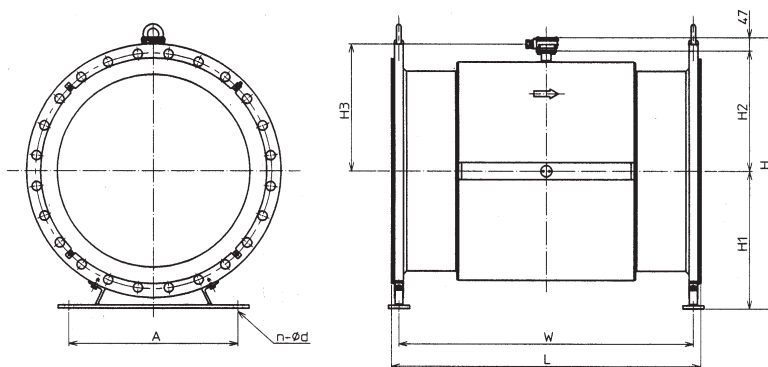

Flange type (size 1000, 1100 mm (40, 44 inches))

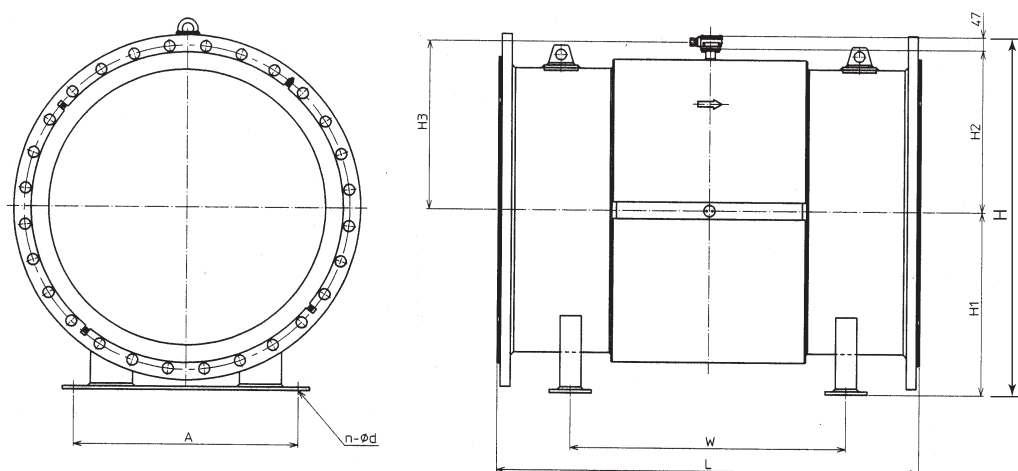

Size		mm	700	800	900	1000	1100
		(inches)	(28)	(32)	(36)	(40)	(44)
Face to face dimension	L	mm	1100	1200	1300	1500	1500
		(inches)	(43.31)	(47.24)	(51.18)	(59.06)	(59.06)
Height	H	mm	979	1080	1211	1278	1399
		(inches)	(38.54)	(42.52)	(47.68)	(50.31)	(55.08)
	H1	mm	503	554	634	650	720
		(inches)	(19.80)	(21.81)	(24.96)	(25.59)	(28.35)
	H2	mm	429	480	530	581	632
		(inches)	(16.89)	(18.90)	(20.87)	(22.87)	(24.88)
H3	mm	454	505	555	606	657	
	(inches)	(17.87)	(19.88)	(21.85)	(23.86)	(25.87)	
Feet length	W	mm	1049	1145	1245	980	1000
		(inches)	(41.30)	(45.08)	(49.02)	(38.58)	(39.37)
Feet width	A	mm	600	600	600	800	800
		(inches)	(23.62)	(23.62)	(23.62)	(31.50)	(31.50)
Feet halls *	n-φd	mm	4-φ33	4-φ33	4-φ33	4-φ33	4-φ33
		(inches)	(1.30)	(1.30)	(1.30)	(1.30)	(1.30)
Weight		kg	630.0	720.0	1060.0	1320.0	1540.0
		(lb)	(1389)	(1587)	(2337)	(2910)	(3395)

Note) The table indicates dimensions for ANSI 150 flange.

\*: n = number, d = diameter

Note

# Note

Note

**azbil**

**Yamatake Corporation**  
**Advanced Automation Company**

1-12-2 Kawana, Fujisawa  
Kanagawa 251-8522 Japan

**URL:**<http://www.azbil.com>